



**FOLGER ADAM SECURITY INC.**

A member of the Yale Security Group



## 700 Series Parts Manual

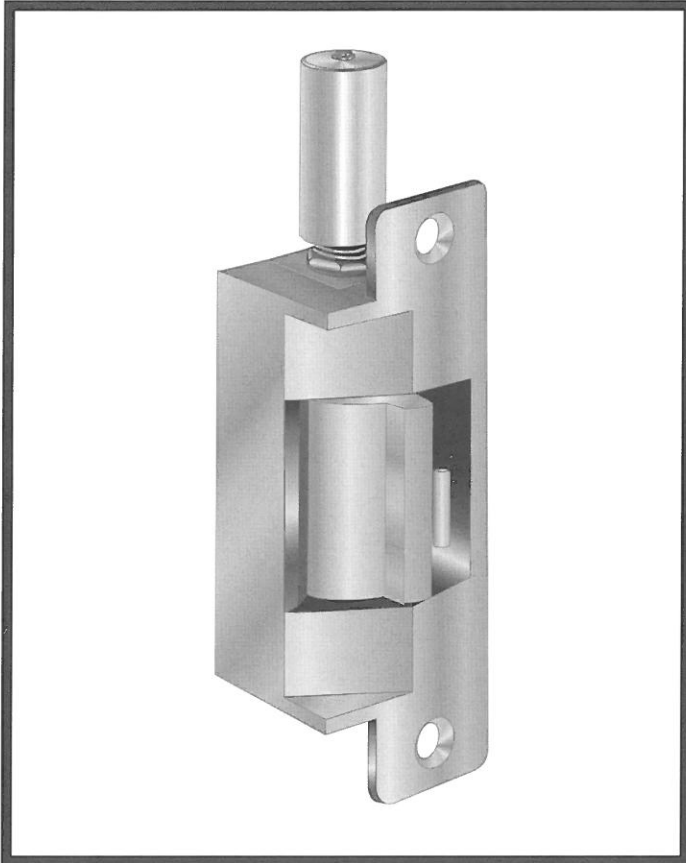



FOLGER ADAM SECURITY INC.  
A member of the Yale Security Group

# 700 Series Parts

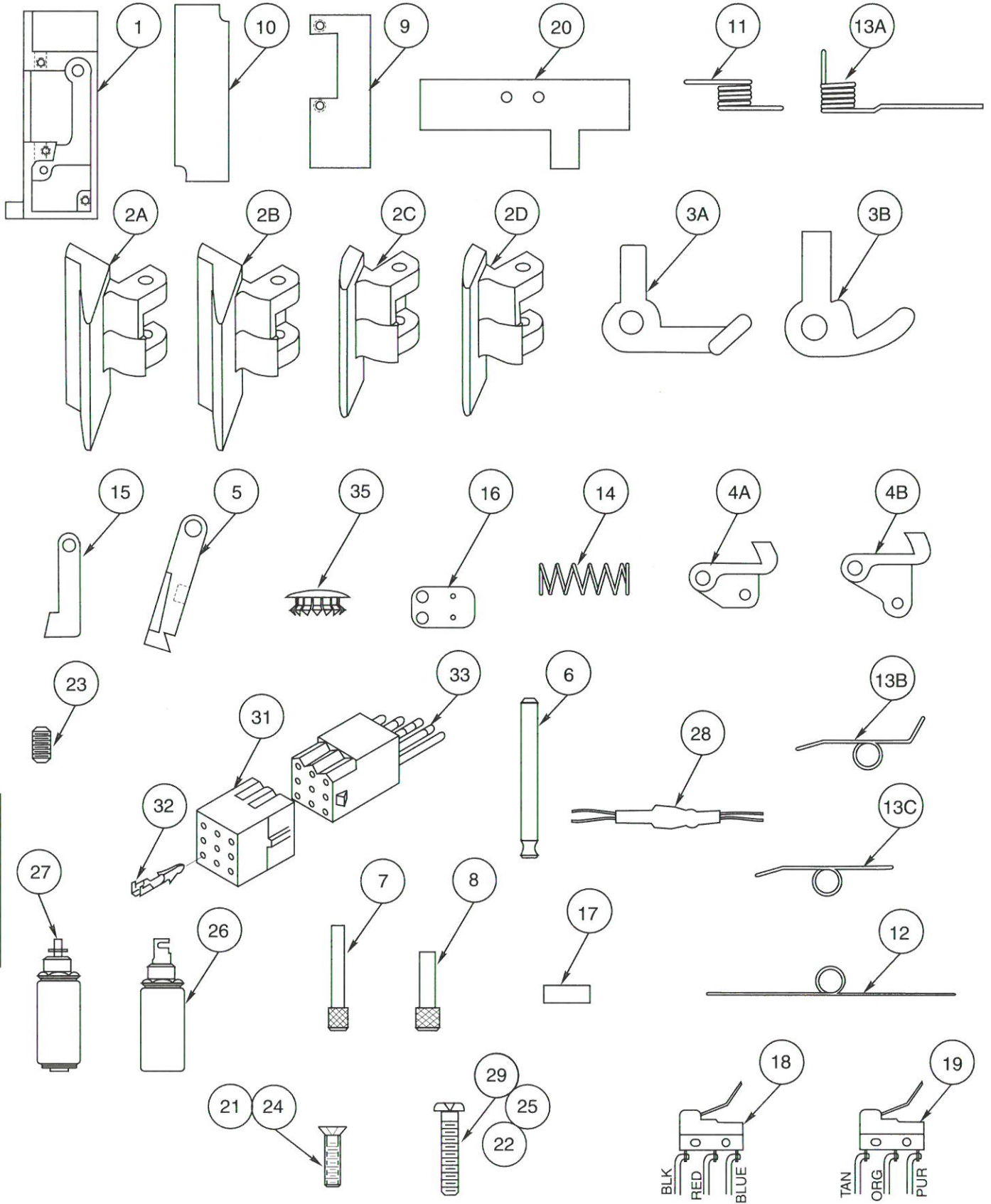



**700 STRIKE ASSEMBLY**  
**710 Strike**

**Front View**  
**Push Type Solenoid / FS**

Lightning Grease  
Pins & Bottom of  
Case before Assmely

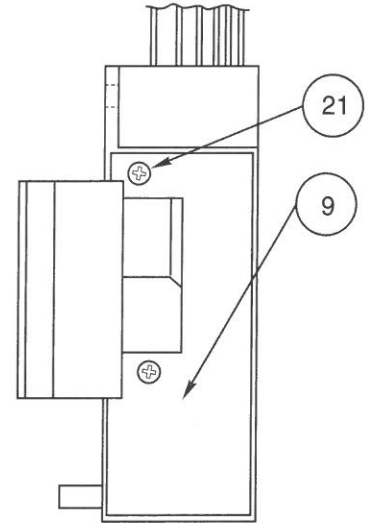
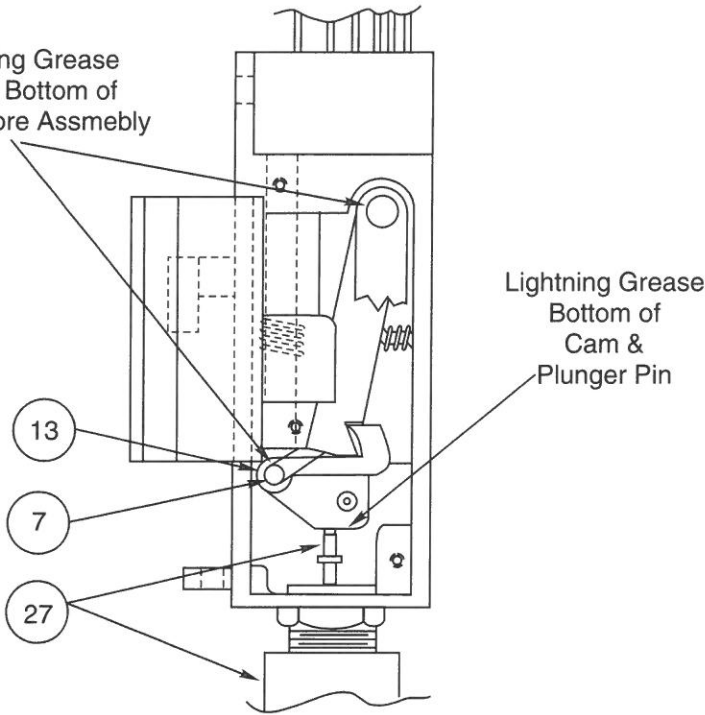

**700-75 Strikes Shown**  
**with 3/4 Latch Keeper and**  
**Switch Tripper for 3/4 Bolts**

**Back View Pull Type Sol / FL**  
**LBM-LCM**

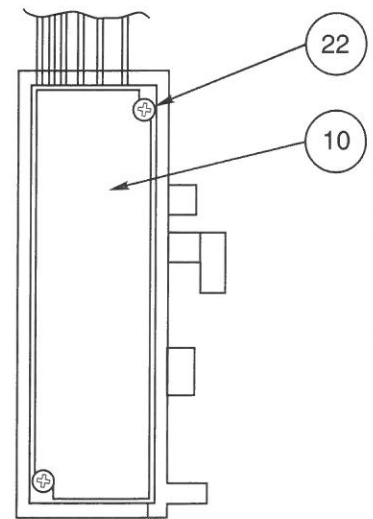
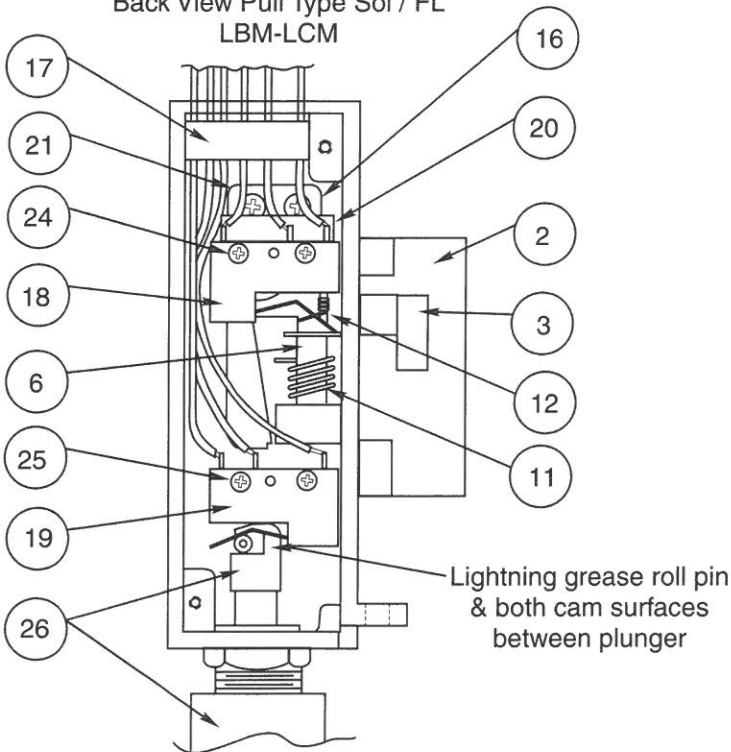

**700 Series**



# 700 STRIKE ASSEMBLY 730 Strike

Front View  
Push Type Solenoid / FS

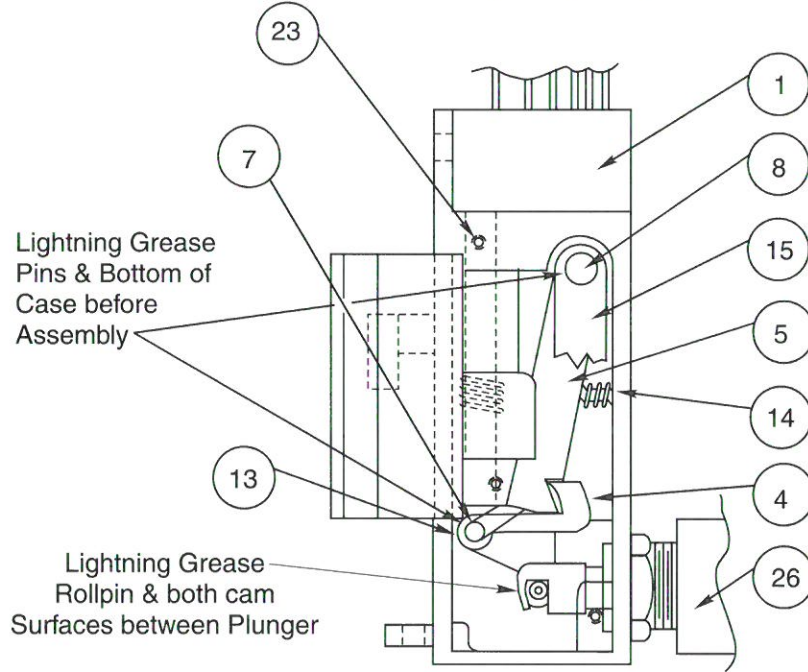

Back View Push Type Sol./fl.  
LBM-LCM / LCMA Switch

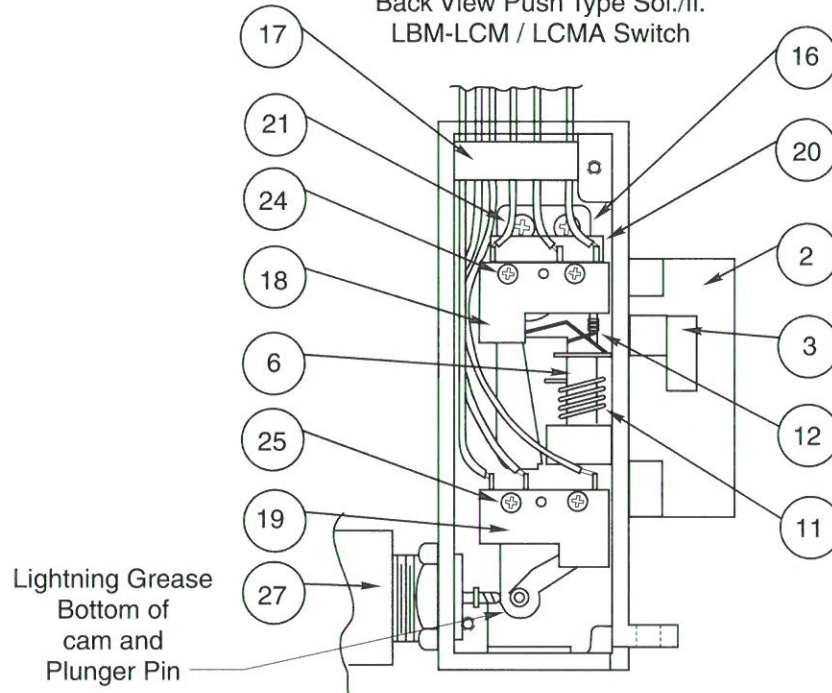

700 Series

# 700 Series Parts .....



**FOLGER ADAM SECURITY INC.**  
A member of the Yale Security Group

Item	Description	Part Number
1	Case Assembly	076-0007-001
4A	Locking Cam Assembly 710-720	076-0200-001
4B	Locking Cam Assembly 730	011-0201-001
5	Locking Lever	012-0612-001
6	Latch Keeper Pin	011-0600-001
	Latch Keeper Pin w/notch	011-0603-001
7	Locking Cam Pin	011-0601-001
8	Locking Lever Pin	011-0602-001
9	Front Cover Plate Old Style	008-0600-001
	Front Cover Plate	008-0605-001
10	Back Cover Plate	008-0601-001
11	Latch Keeper Spring	003-0256-001
12	Switch Tripper Spring	003-0207-001
13A	Locking Cam Spring FS 710 FS 730	003-0209-001
13B	Locking Cam Spring NFS 710	003-0208-001
13C	Locking Cam Spring NFS 730	003-0202-001
14	Compression Spring-Lever	003-0007-001
15	Baffle	008-0603-001
16	Switch Mounting Bracket	008-0602-001
17	Strain Relief Insert	005-4905-001
18	Switch Assembly LBM	076-1202-001
19	Switch Assembly LCM	076-1203-001
20	Switch Insulator	005-0719-001
	Switch Insulator US4	002-2301-031
	Switch Insulator US26D	002-2301-035
21	FHPMS 4-40 x 3/16 UC SST	002-2301-387
22	PHPMS 4-40 x 3/16 SST	002-2303-024
23	SSSC 4-40 x 3/16 Coone PTBO	002-1200-005
24	FHPMS 2-56 c 3/8 Zinc	002-2301-361
25	PHPMS 2-56 x 3/8 Zinc	002-2303-133
26	Solenoid Assembly Pull 6VDC	076-0107-001
	Solenoid Assembly Pull 12VDC	076-0107-002
	Solenoid Assembly Pull 16VDC	076-0107-003
	Solenoid Assembly Pull 24VDC	076-0107-004
	Solenoid Assembly Pull 48VDC	076-0107-005
	Solenoid Assembly Pull 115VDC	076-0107-006

**700 Series**





Item	Description	Part Number
27	Solenoid Assembly Push 6VDC	076-0106-001
	Solenoid Assembly Push 12VDC	076-0106-002
	Solenoid Assembly Push 16VDC	076-0106-003
	Solenoid Assembly Push 24VDC	076-0106-004
	Solenoid Assembly Push 48VDC	076-0106-005
	Solenoid Assembly Push 115VDC	076-0106-006
28	Rectifier AY-310 48-120V/700 0-120V	076-0712-006
29	PHPMS 8-32 x 3/8 Zinc	002-2303-375
31	Connector Plug	005-1705-001
32	Connector Contact Pin	005-1707-001
33	Field Receptacle Assembly	075-3513-001
35	Hole Plug 7/16	005-1202-001

**KEEPERS AND SWITCH TRIPPERS**

Item	Description	Part Number
2A	Latch Keeper 3/4	012-0613-001
2B	Latch Keeper 3/4 w/Switch option	012-0614-001
2C	Latch Keeper 1/2	012-0607-001
2D	Latch Keeper 1/2 w/Switch option	012-0608-001
3A	Switch Tripper 1/2-5/8 Bolts	012-0619-001
3B	Switch Tripper 3/4 Bolts	012-0609-001

**KEEPER AND SWITCH TRIPPER NOTE:**

Items 2A, 2B, & 3A used on 700-75 strikes with 1/2-5/8 bolts.

Items 2A, 2B, & 3B used on 700-75 strikes with 3/4 bolts.

Items 2C, 2D, & 3B used on 700 strikes with 1/2-5/8 bolts.

**700 Series Parts**



**FOLGER ADAM SECURITY INC.**  
A member of the Yale Security Group

**700 REPAIR PARTS KIT #254-1000-001**

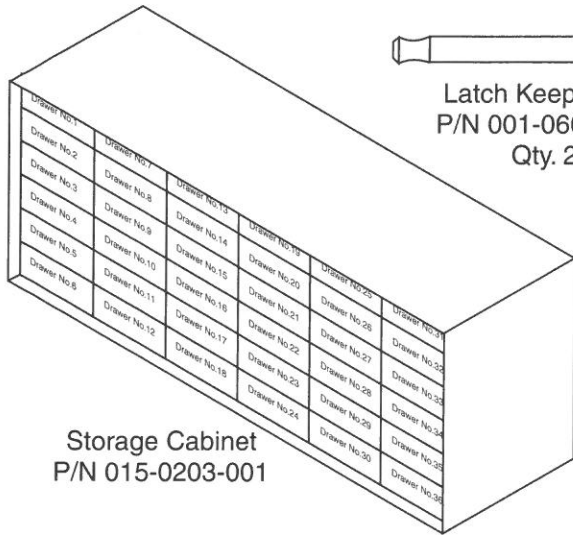

Storage Cabinet  
P/N 015-0203-001

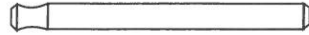

Latch Keeper Pin  
P/N 001-0603-001  
Qty. 2

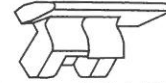

Keeper-LBM 3/4  
P/N 012-0614-001  
Qty. 1

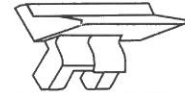

Keeper-LBM  
P/N 012-0608-001  
Qty. 1



Switch Tripper  
700-75 3/4 Bolts 700 1/2-5/8 Bolts  
P/N 012-0609-001  
Qty. 2

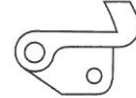

Locking Cam Assy 710  
P/N 076-0200-001  
Qty. 2

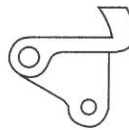

Locking Cam Assy 730  
P/N 076-0201-001  
Qty. 2



Locking Lever  
P/N 012-0612-001  
Qty. 2

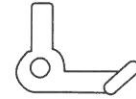

Switch Tripper  
700-75 1/2-5/8 Bolts  
P/N 012-0619-001  
Qty. 2



Locking Cam Spring 730-FL  
P/N 003-0202-001  
Qty. 5



Locking Cam Spring-FS  
P/N 003-0209-001  
Qty. 10



Switch Tripper Spring  
P/N 003-0207-001  
Qty. 10



Locking Cam Spring 710-FL  
P/N 003-0208-001  
Qty. 10



4-40x3/16 SOC SSC  
P/N 002-1200-005  
Qty. 10



2-56 3/8 FHPMS  
002-2301-361  
Qty. 10



4-40x3/16 FHPMS  
P/N 002-2301-387  
Qty. 10

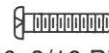

4-40x3/16 PHPMS  
P/N 002-2303-024  
Qty. 10



Keeper Spring  
P/N 003-0256-001  
Qty. 5



Switch Mntg Bracket  
P/N 0008-0602-001  
Qty. 2

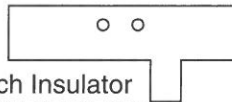

Switch Insulator  
P/N 005-0719-001  
Qty. 10



Compression Spring  
P/N 003-0007-001  
Qty. 10

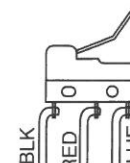

Switch-LCM  
P/N 076-1203-001  
Qty. 5

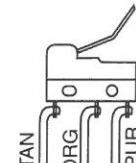

Switch-LBM  
P/N 076-1202-001  
Qty. 5



Solenoid Assy- Pull Type  
12VDC  
P/N 076-0107-002  
Qty. 2



Solenoid Assy- Pull Type  
24VDC  
P/N 076-0107-004  
Qty. 2

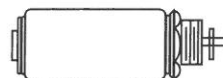

Solenoid Assy- Push Type  
12VDC  
P/N 076-0106-002  
Qty. 2



Solenoid Assy- Push Type  
24VDC  
P/N 076-0106-002  
Qty. 2



Rectifier Assy - 700  
0-120V  
P/N 076-0712-006  
Qty. 3



FHPMS 12-24 x 1/2 UC  
P/N 002-2301-031 US4 - Qty. 10  
P/N 002-2301-035 U26D - Qty. 10



2-56 x 3/8 PHPMS  
P/N 002-2303-133  
Qty. 10

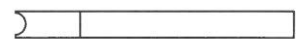

Spring Tool  
P/N 007-0010-001  
Qty. 1

**700 Series**



FOLGER ADAM SECURITY INC.  
A member of the Yale Security Group

# 700 Series Parts

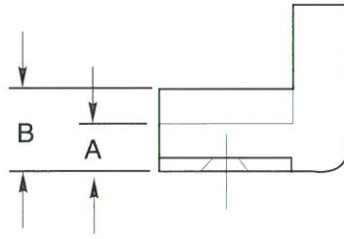
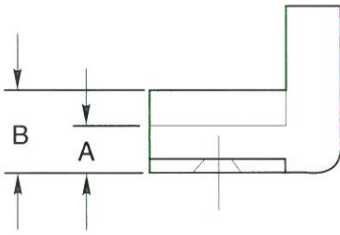

712	A=.50
722	
732	
712-75	B=.75
722-75	
725-75	

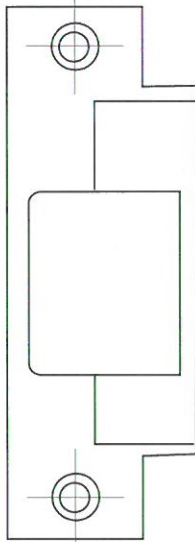

712/732  
Faceplate

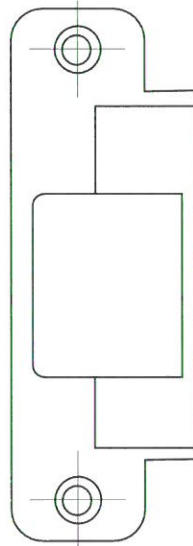

722  
Faceplate

 Junction Box  
Hole Plug

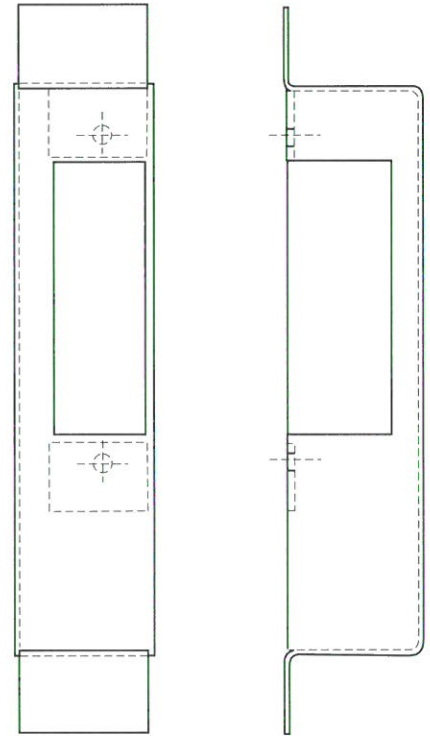

Junction Box

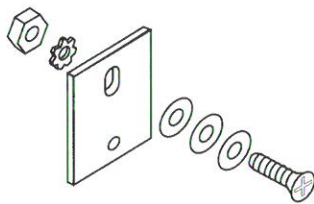

Mounting Tab

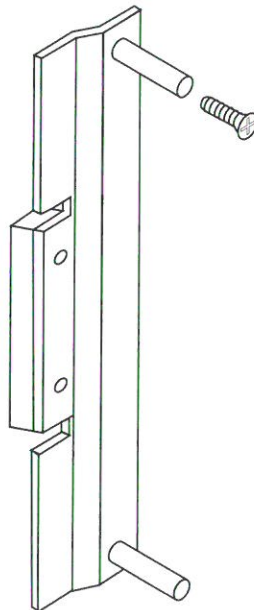

Astragal

700 Series



# 700 Series Parts .....



**FOLGER ADAM SECURITY INC.**  
A member of the Yale Security Group

Finish	712 & 732 Faceplates	712-75 & 732-75 Faceplates
US3	012-0600-002	012-0615-002
US4	012-0600-003	012-0615-003
US10	012-0600-004	012-0615-004
US10B	012-0600-005	012-0615-005
US26	012-0600-006	012-0615-006
US26D	012-0600-007	012-0615-007
US32	012-0600-009	012-0615-009
US32D	012-0600-010	012-0615-010

Finish	FH PHIL MSC 12-24 x 1/2 UC Mounting screws	FH PHIL WSC 12 x 3/4 UC Mounting screws
	Used on: 712, 712-75, 722, 722-75	
US3	002-2301-039	
US4	002-2301-031	002-2300-019
US10	002-2301-032	002-2300-020
US10B	002-2301-033	002-2300-021
US26		002-2300-022
US26D		002-2300-023
US32	002-2301-036	
SST	002-2301-037	

Finish	722 Faceplates	722-75 Faceplates
US32	012-0601-006	012-0617-009
US32D	012-0601-007	012-0617-010
DUR	012-0601-008	012-0617-011

Finish	Mounting Tab set w/screws
BRS	076-0803-001
US10	076-0803-002
US10B	076-0803-002
US26	076-0803-003
US26D	076-0803-005

Finish	700 Astragal Assembly	Astragal FH 12-24 x 1-1/4 UC Mounting screws
US4	076-0825-001	076-0803-361
US10	076-0825-002	076-0803-362
US10B	076-0825-003	076-0803-363
US26	076-0825-004	076-0803-364
US26D	076-0825-005	076-0803-364
US3	076-0825-011	076-0803-361

700 Junction Box Hole Plug	
Size 7/8	005-1202-003

Model	700 Junction Boxes
712&722	076-0818-001
732	012-0818-002

**700 Series**



**FOLGER ADAM SECURITY INC.**  
A member of the Yale Security Group

## 700 Series Parts

The following instructions cover all models of the 700 series strike: 710-75, 710, 712-75, 712, 722-75, 722, 730-75, 730, 732-75 and 732.

### INSTALLATION

1. For proper installation of the 700 strike refer to the appropriate template drawing.
2. Prior to installation make the necessary wire connections per the appropriate wiring diagram.
3. Proper operating voltage must be supplied to the strike if it is to function correctly. Voltage at the strike must be within + or - 10% of the required voltage listed on the strike label.
4. To install the strike into the frame opening:
  - A) Position the wiring either down or up or toward the back of the hollow metal frame, making sure that it stays completely out of the way of the strike so as not to pinch it when installing.
  - B) Mount the strike using the screws supplied:

<u>Strike Model</u>
712, 712-75, 722, 722-75
732, 732-75

<u>Mounting Screws</u>
(2) 12-24 x 1/2 FH PHIL MACH SCS
(2) 12 X 3/4 FH PHIL WOOD SCS

5. After installation check the horizontal alignment, be certain that the centerline of the latch bolt is aligned with the centerline of the strike.
6. In case of misalignment there is a 3/16" horizontal adjustment between the strike mechanism and the face plate. To adjust:
  - A) Remove mounting screws.
  - B) Remove strike from frame.
  - C) Loosen the two (2) 8-32 PHPMS.
  - D) Reposition strike and retighten PHPMS screws.
  - E) Reinstall strike in frame.
  - F) Reinstall mounting screws.

### OPERATION

The Folger Adam 700 electric strike is a solenoid operated device.

1. **710 NON-FAIL-SAFE**  
When power is applied the solenoid pushes the locking cam into the unlocked position allowing the door to be opened. If power fails the strike will remain locked.  
  
NOTE: Non-fail-safe strikes for use in fire rated doors can only be operated by momentary contact switching (energized only when the push button is held depressed) and can not be held in the unlocked position.
2. **710 FAIL-SAFE**  
When power is applied the solenoid pushes the locking cam into the locked position and the door can not be opened. If power fails the strike will unlock.
3. **730 NON-FAIL-SAFE**  
When power is applied the solenoid pushes the locking cam into the unlocked position allowing the door to be opened. If power fails the strike will remain locked.  
  
NOTE: Non-fail-safe strikes for use in fire rated doors can only be operated by momentary contact switching (energized only when the push button is held depressed) and can not be held in the unlocked position.
4. **730 FAIL-SAFE**  
When power is applied the solenoid pulls the locking cam into the locked position and the door can not be opened. If power fails the strike will unlock.



## OPTIONAL FEATURES

1. **LBM SWITCH (Latch Bolt Monitor)**  
A switch operated by the switch tripper that signals whether or not the latch bolt is extended into the strike.
2. **LCM SWITCH (Locking Cam Monitor)**  
A switch operated by the roll pin on the locking cam that monitors the position of the locking cam and signals that the strike is either locked or unlocked.
3. **LBMLCM SWITCH (Locking Cam and Latch Bolt Monitor)**  
A combination of the LCM and LBM switches. By wiring these two switches together, externally, they will indicate that the strike is locked (LCM) and the latch bolt is extended (LBM) into the strike.

4. **SOLENOID VOLTAGE**  
24VDC is standard. Optional voltages available are 6, 12, 16, 48, or 115VDC or VAC.

When control power source is AC, the strike is supplied with an externally attached bridge rectifier.

When control power source is DC, the strike is supplied without the bridge rectifier.

NOTE: UL requires that a junction box be used with 48 and 120 volt strikes, if they are not installed in a back box.

5. **FAIL-SAFE**  
The strike is locked when energized. This feature should be used for applications that require automatic unlocking in case of power failure.

CAUTION: Fail-safe is not permitted with the UL Fire Door Accessory label.

6. **MOUNTING TAB**  
The mounting tab is designed to be used with 712, 712-75, 722 and 722-75 electric strikes when mounting in metal frames.
7. **ASTRAGAL**  
A lock guard, designed to prevent tampering with the strike keeper and the latch bolt.
8. **EXTENDED LIP**  
A lip extension is added to the face plate to form a path for the latch bolt when released electrically. Extension is available in increments of 1/4" up to 2" maximum.



# 700 WIRING DIAGRAMS

## Attachment of New Rectifier

(Required when supplying AC power to a unit with a DC solenoid)

DC Solenoid

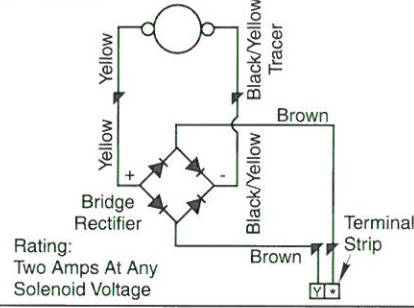

Rating:  
Two Amps At Any  
Solenoid Voltage

## Attachment of Old Rectifier

(Required when supplying AC power to a unit with a DC solenoid)

DC Solenoid

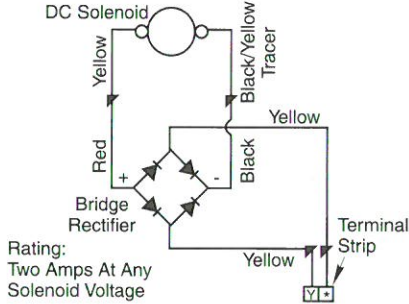

Rating:  
Two Amps At Any  
Solenoid Voltage

## 700 LBMLCM Wiring Diagram

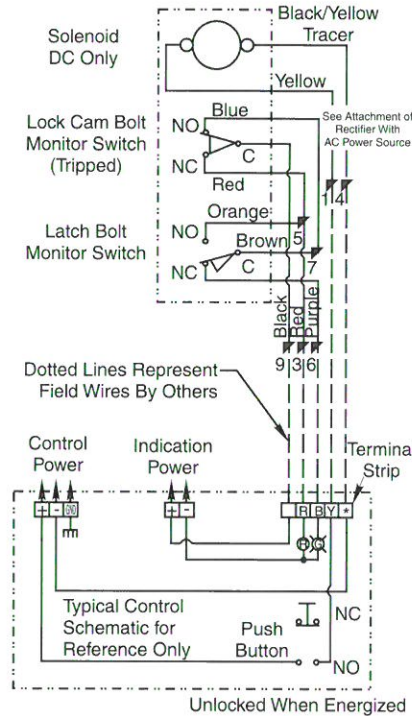

Unlocked When Energized

## 700 LCMA Wiring Diagram

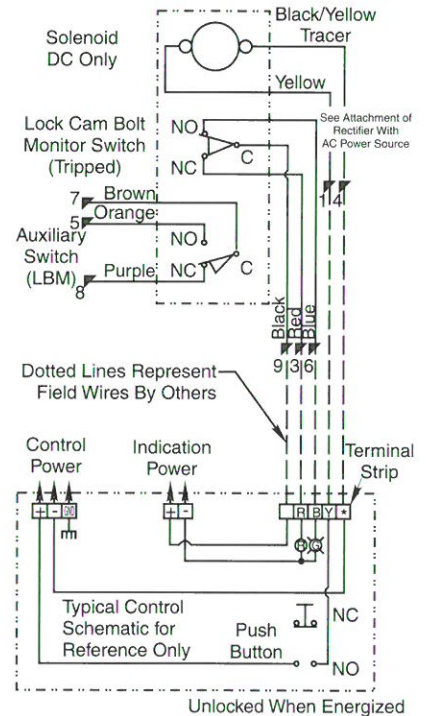

Unlocked When Energized

Electrical Ratings for All 700 Strike Solenoids	Voltage					
	DC					
	6	12	16	24	48	120
Resistance in OHMS ± 10%	10	41	73	160	640	3700
Watts	3.60	3.48	3.52	3.60	3.60	3.84
Amps	.6	.29	.22	.15	.075	.032

### Notice:

Wiring Subject To Change without Notice. Not Responsible when Controls Furnished By Others.

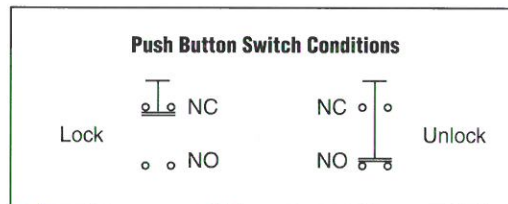



# 700 WIRING DIAGRAMS

## 700 LBM Wiring Diagram

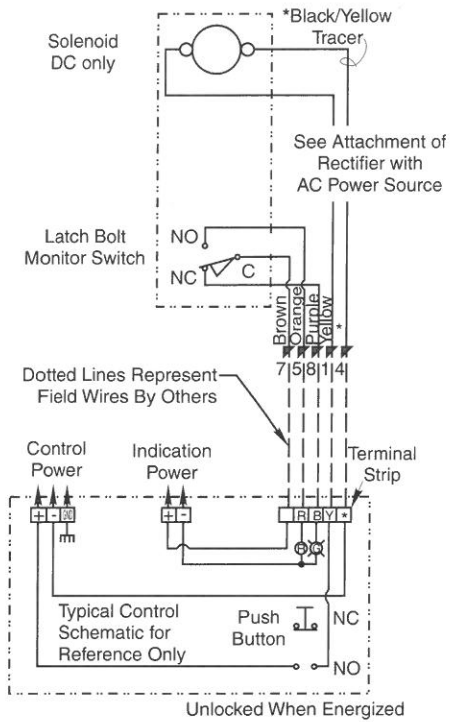

## 700 LCM Wiring Diagram

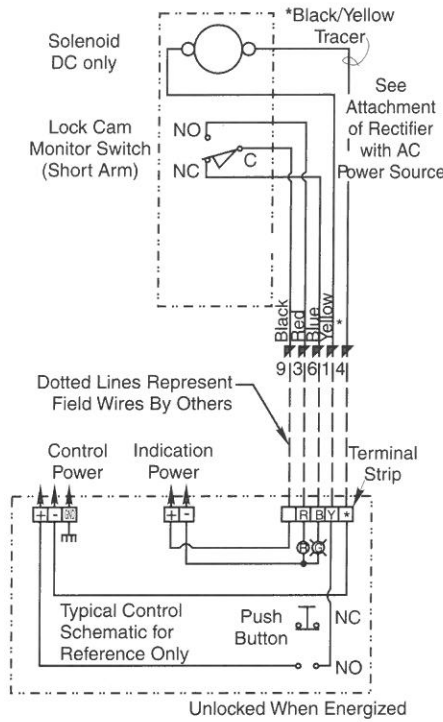

## Fail Safe Controls

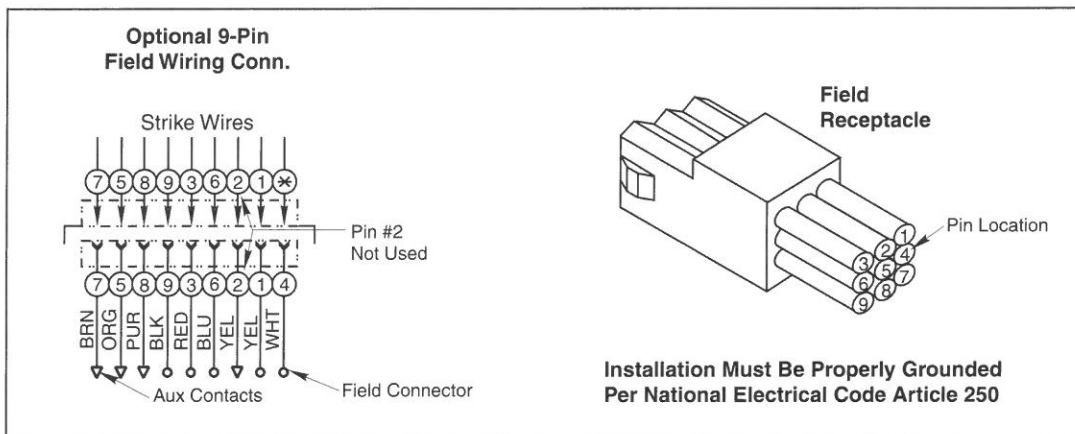
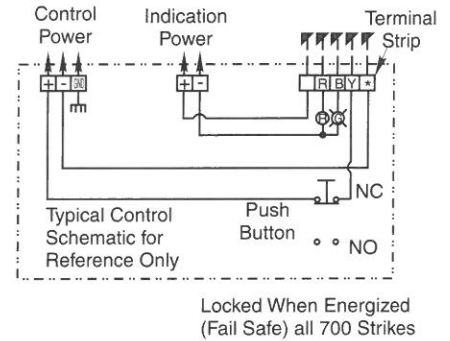

### NOTES:

- 1) \* = Wires color code:  
6 thru 120 VDC  
Yellow/Black Tracer  
12 & 24 VAC-Grey  
120 VAC-White
- 2) Unused wires to be individually isolated with a wire nut or equal.
- 3) Numbered field connections refer to pin location in field receptacle.





**MAINTENANCE AND LUBRICATION**

Under normal usage the 700 electric strike should be cleaned and lubricated once a year to maintain its reliability. In applications with high usage or dirty conditions more frequent service may be necessary. When servicing a 700 inspect the internal parts for excess wear or breakage and lightly lubricate. Lubricate with Lightning Grease, available from Folger Adam. Never lubricate any strike with oil, such lubrication collects dirt and forms an abrasive and sticky compound that may affect the function of the strike.

**TO INSPECT AND LUBRICATE THE STRIKE:**

1. Remove the strike from the face plate, held on by two (2) 8-32 x 3/8 PHPMS.
2. Remove the front cover, held on by two (2) 4-40 x 3/16 FHMS. Removal of the front cover should be done slowly because the locking cam spring may snap out of place. Also, care should be taken to insure that the baffle is not lost.
3. Remove the cam spring and the baffle.
4. PULL TYPE: Loosen the lock nut holding the solenoid, then remove the solenoid and then the plunger.  
PUSH TYPE: Loosen the lock nut holding the solenoid, then remove the solenoid and plunger assembly.
5. Remove the locking cam.
6. Remove the locking lever spring and locking lever.
7. Lubricate the area in the case where the locking lever and locking cam rest. (Be careful not to get any lubricant on the solenoid or switches.) Lubricate the cam pin and lever pin.
8. Check the locking angle of the keeper and locking lever for wear. Replace the keeper and/or lever if worn. (If the keeper is disassembled for replacement or adding of a switch, lubricate the keeper pin.)
9. Reinstall the locking lever and the locking lever spring, the spring must be held compressed into the hole in the locking lever for installation.
10. Check the solenoid, plunger and plunger guide for excess wear, dirt, grime or oil, if present wipe clean.  
PUSH TYPE: Remove the retaining ring for inspection of the plunger guide. Re-assemble the solenoid and plunger with a new retaining ring.
11. PULL TYPE: Lubricate the roll pin and the locking cam surfaces between the solenoid plunger (contact points of the solenoid plunger).  
PUSH TYPE: Lubricate the edge of the locking cam (contact point of the solenoid plunger).
12. Reinstall the locking cam. If the strike has a LCM or LBMLCM switch make sure the roll pin on the locking cam is positioned in front of the switch actuator arm.

700 Series

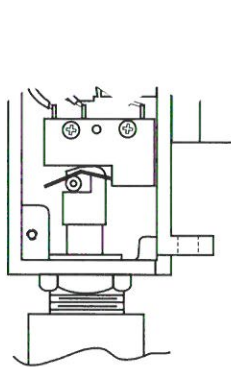

730 Non-Fail Safe  
732

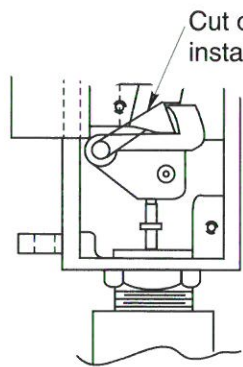

730 Non-Fail Safe  
732

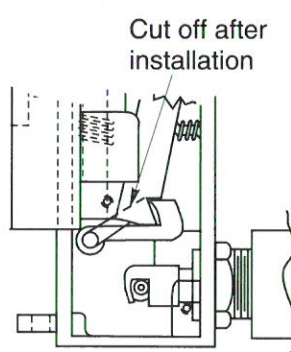

710 Fail Safe  
712  
722

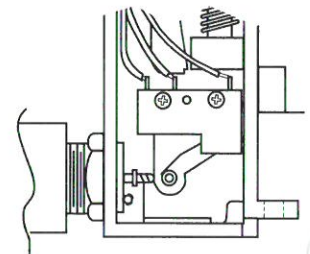

710 Non-Fail Safe  
712  
722





## 13. INSTALLING AND ADJUSTING THE SOLENOID

A) 710 NON-FAIL-SAFE: In the bottom hole in the case, install the plunger with the opening for the roll pin toward the lever side of the case, then install the solenoid.

730 NON-FAIL-SAFE: In the back hole in the case, install the solenoid and plunger assembly.

710 FAIL-SAFE: In the bottom hole in the case, install the solenoid and plunger assembly.

730 FAIL-SAFE: In the back hole in the case, install the plunger with the opening for the roll pin toward the bottom of the case, then install the solenoid.

B) 710 & 730 NON-FAIL-SAFE: Install the locking cam spring with the L-shaped leg of the spring on the bottom of the locking cam (plunger side) and the other leg in the groove in the side of the case. See illustrations.

710 & 730 FAIL-SAFE: Install the locking cam spring with the L-shaped leg of the spring on the top of the locking cam (locking lever side) and the other leg in the groove in the case (near the locking lever). See illustrations.

C) 710 NON-FAIL-SAFE (Pull Type): Before tightening the lock nut, energize the solenoid and adjust the solenoid position until the locking cam is pulled into the unlocked position, tighten the lock nut on the solenoid.

710 FAIL-SAFE (Push Type): Before tightening the lock nut, energize the solenoid and adjust the solenoid position until the solenoid plunger pushes the locking cam into the locked position (do not screw in the solenoid more than required or the solenoid plunger will not seat in the solenoid). De-energize the solenoid and check that the locking cam moves to the unlocked position. Tighten the solenoid lock nut.

730 NON-FAIL-SAFE (Push Type): Before tightening the lock nut, energize the solenoid and adjust the solenoid position until the solenoid plunger pushes the locking cam into the unlocked position, tighten the lock nut on the solenoid.

730 FAIL-SAFE (Pull Type): Before tightening the lock nut, energize the solenoid and adjust the solenoid position until the locking cam is pulled into the locked position. De-energize the solenoid and check that the locking cam moves to the unlocked position, tighten the solenoid lock nut.

HINT: Hold cam spring in place or place cover over cam spring before energizing solenoid.

14. Check all screws, tighten if necessary. CAUTION: Do not over tighten the switch screws, over tightening could break the switch.
15. Reinstall the baffle.
16. Reinstall the front cover.
17. Re-assemble the strike to the face plate.

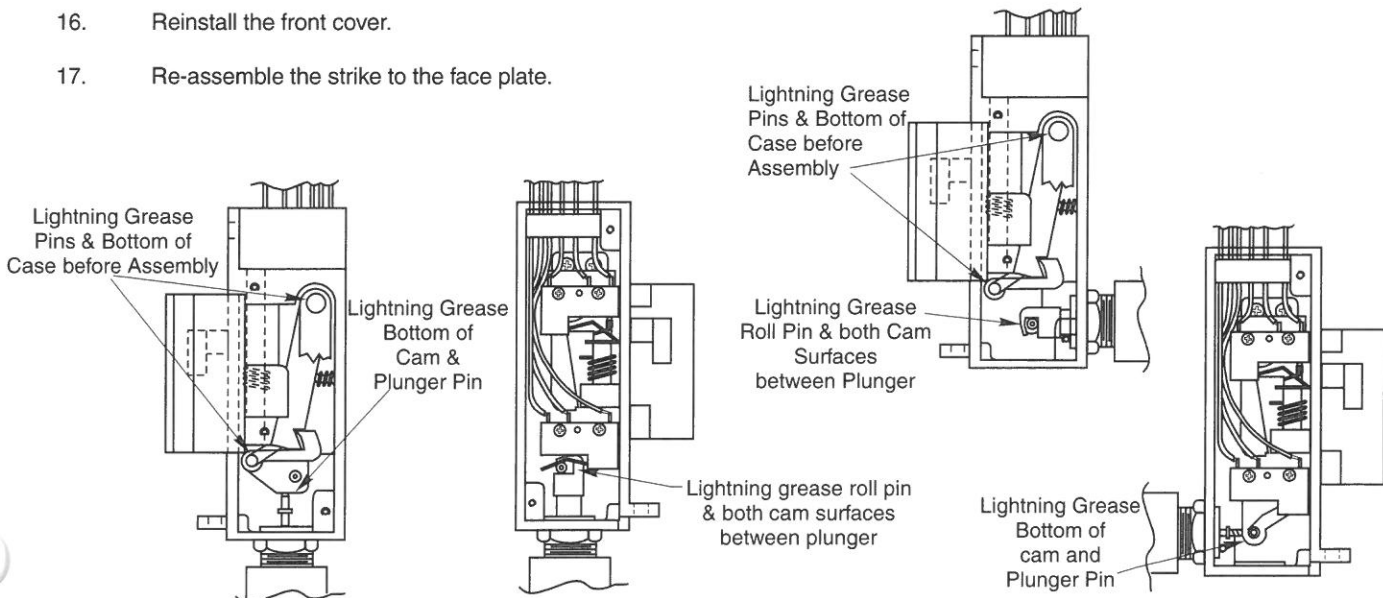

**700 Series**



## CHANGING SOLENOIDS AND CHANGING STRIKE MODEL

(FS to NON-FS, NON-FS to FS) (710 to 730, 730 to 710)

NOTE: PUSH TYPE solenoids are used in 710 FAIL-SAFE and 730 NON-FAIL-SAFE strikes.  
PUSH TYPE solenoids are used in 710 NON-FAIL-SAFE and 730 FAIL-SAFE strikes.

NOTE: To change from DC to AC a rectifier (item 4, listed below) must be connected to the solenoid with butt splices. To change from AC to DC remove the rectifier by cutting the wire leads.

PARTS:	ITEM	DESCRIPTION	QTY	PART NUMBER
	1A	CamSpring Fail-Safe 710 & 730		003-0209-001
	1B	Cam Spring Non-Fail-Safe 710	1	003-0208-001
	1C	Cam Spring Non-Fail-Safe 730		003-0202-001
		Solenoid Assy Pull 6VDC		076-0107-001
		Solenoid Assy Pull 12VDC		076-0107-002
	2A	Solenoid Assy Pull 16VDC	1	076-0107-003
		Solenoid Assy Pull 24VDC		076-0107-004
		Solenoid Assy Pull 48VDC		076-0107-005
		Solenoid Assy Pull 115VDC		076-0107-006
		Solenoid Assy Push 6VDC		076-0106-001
		Solenoid Assy Push 12VDC		076-0106-002
	2B	Solenoid Assy Push 16VDC	1	076-0106-003
		Solenoid Assy Push 24VDC		076-0106-004
		Solenoid Assy Push 48VDC		076-0106-005
		Solenoid Assy Push 115VDC		076-0106-006
	3A	Locking Cam Assy 710	1	076-0200-001
	3B	Locking Cam Assy 730	1	076-0201-001
	4	Rectifier for AC	1	076-0710-001

### INSTRUCTIONS FOR CHANGING A:

- 710 NFS to a 710 FS (new solenoid and cam spring required, Items 1A and 2B)
- 710 FS to a 710 NFS (new solenoid and cam spring required, Items 1B and 2A)
- 730 NFS to a 730 FS (new solenoid and cam spring required, Items 1A and 2A)
- 730 FS to a 730 NFS (new solenoid and cam spring required, Items 1C and 2B)

1. Remove the strike from the face plate, held on by two (2) 8-32 x 3/8 PHPMS.
2. Remove the front cover, held on by two (2) 4-40 x 3/16 FHMS. Removal of the front cover should be done slowly because the locking cam spring may snap out of place. Also care should be taken to insure that the baffle is not lost.
3. Remove the cam spring and the baffle.
4. PULL TYPE: Loosen the lock nut holding the solenoid, then remove the solenoid and then the plunger.  
PUSH TYPE: Loosen the lock nut holding the solenoid, then remove the solenoid and plunger assembly.
5. Refer to the instructions for INSTALLING AND ADJUSTING THE SOLENOID (see page 15, Item 13).
6. Reinstall the baffle.
7. Reinstall the front cover.
8. Re-assemble the strike to the face plate.
9. Refer to the appropriate wiring diagram for wire connections.

## 700 Series Parts .....



FOLGER ADAM SECURITY INC.  
A member of the Yale Security Group

### INSTRUCTIONS FOR CHANGING A:

710 NFS to a 730 FS (same solenoid, new cam and cam spring, Items 1A and 3B)  
710 NFS to a 730 NFS (new solenoid, cam and cam spring, Items 1C, 2B and 3B)  
710 FS to a 730 FS (new solenoid and cam, same cam spring, Items 2A and 3B)  
710 FS to a 730 NFS (same solenoid, new cam and cam spring, Items 1C and 3B)

1. Remove the strike from the face plate, held on by two (2) 8-32 x 3/8 PHPMS.
2. Remove the front cover, held on by two (2) 4-40 x 3/16 FHMS. Removal of the front cover should be done slowly because the locking cam spring may snap out of place. Also care should be taken to insure that the baffle is not lost.
3. Remove the cam spring and the baffle.
4. PULL TYPE: Loosen the lock nut holding the solenoid, then remove the solenoid and then the plunger. Remove the locking cam.  
PUSH TYPE: Loosen the lock nut holding the solenoid, then remove the solenoid and plunger assembly. Remove the locking cam.
5. Remove the hole plug and reinstall it in the opposite hole in the case (bottom).
6. A) Lubricate the area in the case where the locking cam rests. Lubricate the cam pin.  
B) Lubricate the edge of the locking cam (contact point of the solenoid plunger).  
NOTE: Apply lubricant very lightly!! Be careful not to get any lubricant on the solenoid or switches.  
C) Install the new locking cam. Make sure that the locking cam does not drag. If the strike has a LCM or LBMLCM switch make sure the roll pin on the locking cam is positioned in front of the switch actuator arm.
7. Refer to the instructions for INSTALLING AND ADJUSTING THE SOLENOID.
8. Reinstall the baffle.
9. Reinstall the front cover.
10. Re-assemble the strike to the face plate.
11. Refer to the appropriate wiring diagram for wire connections.

### INSTRUCTIONS FOR CHANGING A:

730 FS to a 710 FS (new solenoid and cam, same cam spring, Items 2B and 3A)  
730 FS to a 710 NFS (same solenoid, new cam and cam spring, Items 1B and 3A)  
730 NFS to a 710 NFS (new solenoid, cam and cam spring, Items 1B, 2A and 3A) 730 NFS to a 710 FS (same solenoid, new cam and cam spring, Items 1A and 3A)

1. Remove the strike from the face plate, held on by two (2) 8-32 x 3/8 PHPMS.
2. Remove the front cover, held on by two (2) 4-40 x 3/16 FHMS. Removal of the front cover should be done slowly because the locking cam spring may snap out of place. Also care should be taken to insure that the baffle is not lost.
3. Remove the cam spring and the baffle.
4. PULL TYPE: Loosen the lock nut holding the solenoid, then remove the solenoid and then the plunger. Remove the locking cam.  
PUSH TYPE: Loosen the lock nut holding the solenoid, then remove the solenoid and plunger assembly. Remove the locking cam.
5. Remove the hole plug and reinstall it in the opposite hole in the case (back).
6. A) Lubricate the area in the case where the locking cam rests. Lubricate the cam pin.  
B) Lubricate the edge of the locking cam (contact point of the solenoid plunger).  
NOTE: Apply lubricant very lightly!! Be careful not to get any lubricant on the solenoid or switches.  
C) Install the new locking cam. Make sure that the locking cam does not drag. If the strike has a LCM or LBMLCM switch make sure the roll pin on the locking cam is positioned in front of the switch actuator arm.
7. Refer to the instructions for INSTALLING AND ADJUSTING THE SOLENOID. (See page 15, item 13.)
8. Reinstall the baffle.
9. Reinstall the front cover.
10. Re-assemble the strike to the face plate.
11. Refer to the appropriate wiring diagram for wire connections.





### INSTRUCTION FOR ADDING A LCM SWITCH

<b>PARTS REQUIRED:</b>	<b>Description</b>	<b>Qty</b>	<b>Part Number</b>
	LCM Switch Assembly	1	076-1203-001
	Switch Insulator	1	005-0719-001
	RHMS 2-56 x 3/8 Zinc	2	002-2100-133
	Strain Relief Insert	1	005-4905-001

1. Remove the strike from the face plate, held on by (2) 8-32 x 3/8 PHPMS.
2. Remove the back cover by loosening the two (2) 4-40 x 3/16 PHMS. If the strike has a LBM switch care should be taken to insure that the strain relief is not lost, remove the strain relief.
3. Bend the switch actuator arm per the illustration, before installation. Install the switch and insulator with the roll pin on the locking cam in front of the switch actuator arm. Secure the switch in place with the two (2) 2-56 x 3/8 RHMS. The switch actuator arm must be adjusted to actuate when the locking cam is in the locked position. See illustration. Reposition the wires and fasten the insulator over the switch.
4. Install the strain relief insert.
5. Reinstall the back cover.
6. Reassemble the strike to the face plate.
7. Refer to the appropriate wiring diagram for wire connections.

**Rear View Shown with LCM Switch**

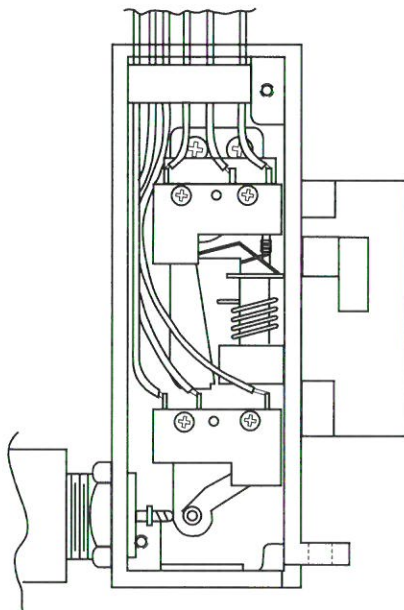

**Rear View Shown with LBM Switch**

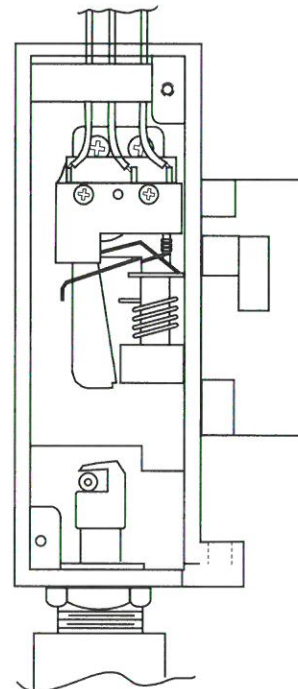

### INSTRUCTION FOR ADDING A LBMLCM SWITCH

Refer to instructions for adding LCM and LBM switches. Increase the quantity of switch insulators to two (2).

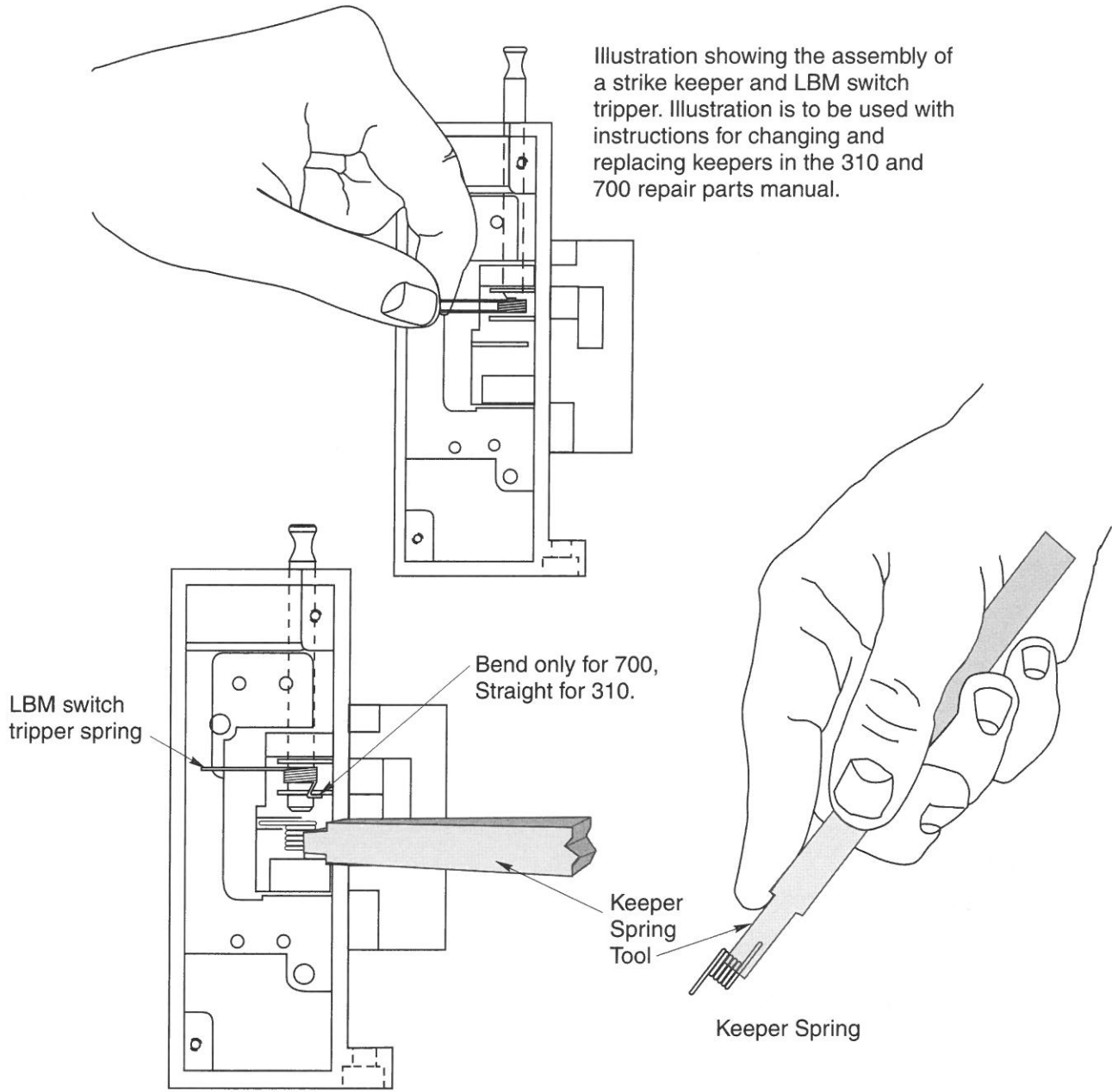

Illustration showing the assembly of a strike keeper and LBM switch tripper. Illustration is to be used with instructions for changing and replacing keepers in the 310 and 700 repair parts manual.

LBM switch tripper spring

Bend only for 700, Straight for 310.

Keeper Spring Tool

Keeper Spring

**To remove a 310 Strike Knurled Keeper Pin:**

- 1) Using a punch and hammer, Place the punch against the bottom of the keeper pin (as shown below).
- 2) Tap the keeper pin out of the case until the knurled portion of the pin is outside of the case.
- 3) Pull the keeper pinout with pliers.

If the 310 strike has a set screw to hold the keeper pin in place. Loosen the set screw and push the keeper pin out of the case.

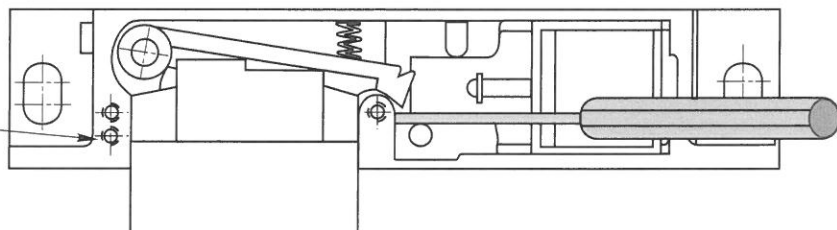

700 Series



## INSTRUCTION FOR ADDING A LBM SWITCH

Special Tool Required: Keeper Spring Tool, 007-0010-001

	<u>Description</u>	<u>Qty</u>	<u>Part Number</u>
<b>PARTS REQUIRED:</b>	LBM Switch Assembly	1	076-1202-001
	Switch Tripper Spring	1	003-0207-001
	Switch Insulator	1	005-0719-001
	FHMS 2-56 x 3/8 Zinc	2	002-1900-361
	Switch Mounting Bracket	1	008-0602-001
	FHMS 4-40 x 3/8 SST	2	002-1900-387
	Keeper for Switch 1/2 700		012-0608-001
	Keeper for Switch 3/4 700-75		012-0614-001
	Strain Relief Insert	1	005-4905-001
	<u>Switch Tripper for 700-75 Strikes 1/2-5/8 Bolts</u>		
	Switch Tripper 1/2-5/8 Bolts	1	012-0619-001
<u>Switch Tripper for 700 Strikes 1/2-5/8 Bolts or 700-75 Strikes 3/4 Bolts</u>			
Switch Tripper 3/4 Bolts	1	012-0609-001	

1. Remove the strike from the face plate, held on by two (2) 12-24 x 3/8 HEX WASHER HEAD CAP SCS.
2. Remove the front cover, held on by two (2) 4-40 x 3/16 FHMS. Removal of the front cover should be done slowly because the locking cam spring may snap out of place. Also, care should be taken to insure that the baffle is not lost.
3. Remove the cam spring and the baffle.
4. PULL TYPE: Loosen the lock nut holding the solenoid, then remove the solenoid and then the plunger.
5. Remove the locking cam.
6. Remove the back cover by loosening the two (2) 4-40 x 3/16 PHMS. If the strike has a LCM switch, care should be taken to insure that the strain relief is not lost, remove the strain relief.
7. Change the keeper (see instructions for CHANGING AND REPLACING THE KEEPER).
8. Install the switch mounting bracket with the two (2) 4-40 x 3/16 FHMS.
9. Bend the switch actuator arm per the illustration, before installation. Install the switch and insulator on the switch mounting bracket with the actuator arm in behind the switch tripper leg. Tighten the switch mounting screws. The switch actuator arm must be adjusted to actuate when the switch tripper is rotated away from the keeper, see illustration. Reposition the wires and fasten the insulator over the switch.
10. Install the strain relief insert.
11. Reinstall the back cover.
12. Reinstall the locking cam. If the strike has a LCM or LBMLCM switch make sure the roll pin on the locking cam is positioned in front of the switch actuator arm.
13. Refer to the instructions for INSTALLING AND ADJUSTING THE SOLENOID.
14. Reinstall the baffle.
15. Reinstall the front cover.
16. Reassemble the strike to the face plate.
17. Refer to the appropriate wiring diagram for wire connections.





## CHANGING AND REPLACING THE KEEPER

Special tool Required: Keeper Spring Tool, 007-0010-001

Note: During the first quarter of 1987 a change was made to the case and keeper pin. One radius groove was removed from the keeper pin. One of the cover mounting holes was relocated on the case. Strikes produced after the fourth quarter of 1986 have changes made to the case and keeper pin.

1. TO REMOVE THE KEEPER:
  - A) Loosen the SSSC holding the keeper pin.
  - B) Push the keeper out of the case from the bottom (near the cam pin) until the end of the pin is outside of the case at the top of the strike.
  - C) The keeper pin can then be pulled out with pliers.
2. TO INSTALL A KEEPER, use the instructions listed below: (see page 19)
  - A) Lubricate the keeper pin and both hubs of the keeper, the contact areas with the case walls.
  - B) KEEPER WITH A SWITCH TRIPPER: Lubricate both hubs of the switch tripper.
  - C) Position the keeper in the case and insert the keeper pin (through the hole in the top of the case) through the first hub of the keeper.
  - D) KEEPER WITH A SWITCH TRIPPER: Position the switch tripper in the case and push the keeper pin ( through the hole in the top of the case) through the first hub of the keeper.
  - E) KEEPER WITH A SWITCH TRIPPER: With the switch tripper spring legs bent toward the circle of the spring, insert the switch tripper spring and push the keeper pin through the switch tripper spring and the second hub of the switch tripper.
  - F) Cut approximately 1/8" off one leg of the keeper spring. Using the keeper spring tool insert the long leg of the keeper spring into the tool, then push the keeper spring into position in the keeper with the short leg of the keeper spring positioned in the slot in the keeper.
  - G) Push the keeper pin through the spring, the second hub of the keeper, then into the hole in the cases until flush.
  - H) Tighten the SSSC to secure the keeper pin.
  - I) KEEPER WITH A SWITCH TRIPPER: Bend the leg of the switch tripper spring near the lever, approximately 3/8" from the end of the leg, into a L-shape. Pull up the other leg and bend it around the switch tripper, then cut approximately 7/8" off.



## TROUBLESHOOTING

### PROBLEM

Strike does not operate when energized.

Strike operates intermittently.

Solenoid overheating or burned out.

Strike is not re-locking or is not unlocking.

Improper indication.  
(LCM, LBM OR LBMLCM)

Solenoid plunger binding  
(Plunger will not extend or retract).

### SOLUTION

Check for proper voltage being supplied to the strike.  
Check all wiring.  
Check the coil resistance of the solenoid and compare it to the chart located on the wiring diagram, to insure the correct solenoid is being used.

Check for loose wire connection.

Check for proper voltage being supplied to the strike.

Check for proper alignment between strike keeper and bolt, realign face plate if necessary.  
The keeper may not be returning to the fully locked position.  
Check the strike with the door open, if the strike re-locks check the horizontal alignment between the strike keeper and the latch bolt. There is a 3/16" horizontal adjustment between the strike assembly and the face plate (see installation instructions for adjustment). If vertical alignment is off, reposition the face plate.

Check the locking cam spring to insure it is moving the locking cam into the locked position (non-fail-safe) or the unlocked position (fail-safe).

Check the solenoid assembly to insure the solenoid plunger is moving freely.

Check wiring.  
Check latch bolt for correct engagement with switch tripper.  
Check switch actuator arm, re-bend if necessary.  
Check continuity of indication switches, common to normally open, common to normally closed.

Check alignment between solenoid plunger and cam.