

# 5300/5500 DOOR CLOSER MODELS

PARALLEL ARM INSTALLATION - PUSH SIDE  
NON-HOLD OPEN AND HOLD OPEN APPLICATIONS

TEMPLATE: 539303,  
REV. 2 11-07-19

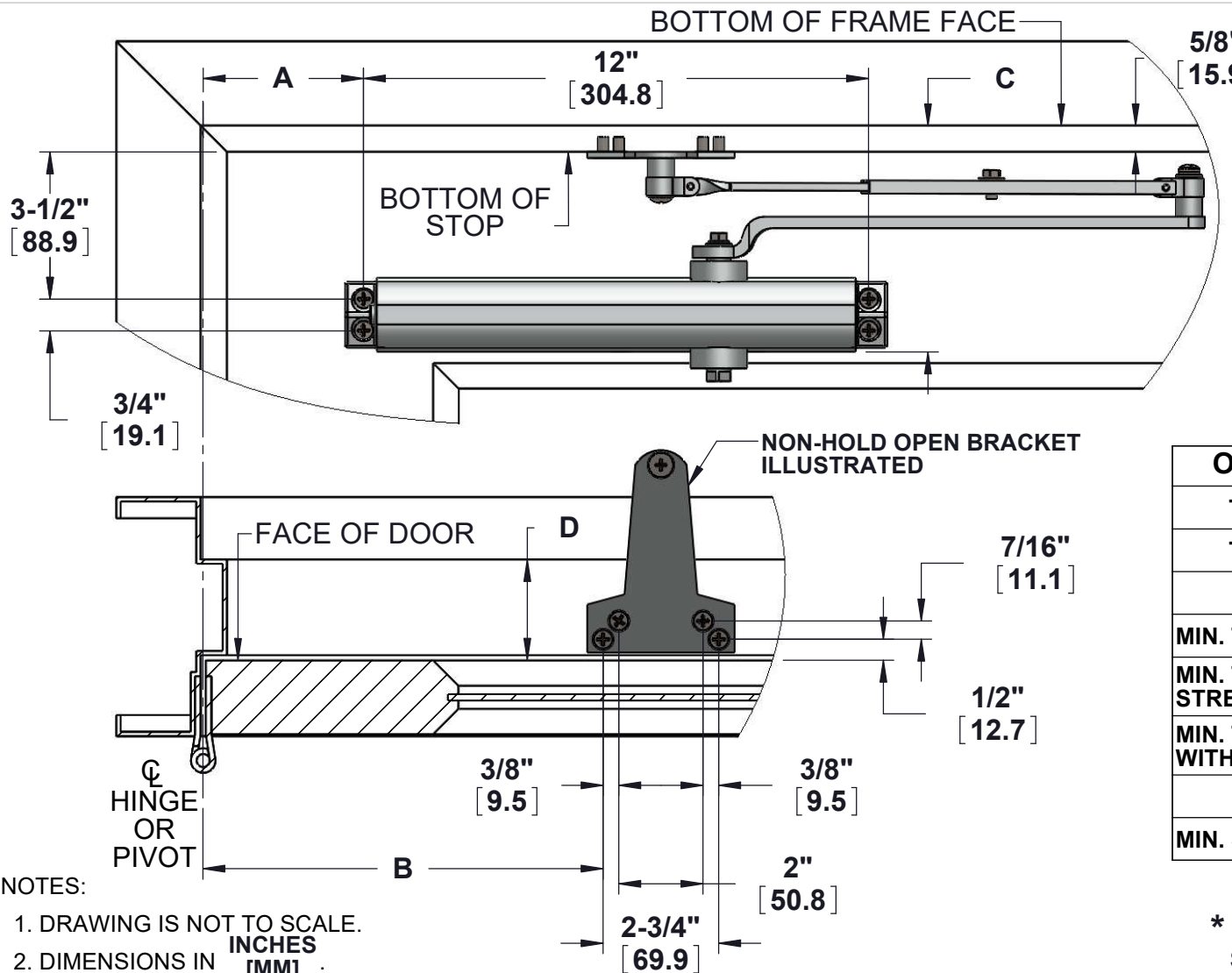

- MACHINE SCREWS:**  
USE #7 OR 13/64" [5.1] DRILL AND 1/4-20 TAP
- WOOD DOOR/FRAME SCREWS:**  
USE 5/32" [4] DRILL
- SEX NUTS:**  
USE 3/8" [9.5] DRILL (CLOSER TO DOOR)

| Opening  | Dim. A         | Dim. B     |
|--|----------------|------------|
| To 120°  | 3-1/4" [95.3]  | 9" [228.6] |
| To 180°  | 1-1/4" [31.8]  | 7" [177.8] |
| Dim C.*  |                |            |
| MIN. TO BOTTOM OF CLOSER                                       | 5-1/4" [133.4] |            |
| MIN. TO BOTTOM OF DUST CAP WITH STREAMLINE COVER - 5300 SERIES | 6" [152.4]     |            |
| MIN. TO BOTTOM OF FULL COVER WITH INSERT - 5500 SERIES         | 6-3/8" [161.9] |            |
| Dim. D   |                |            |
| MIN. STOP DEPTH RECOMMENDED                                    | 1-1/4" [31.8]  |            |

\* MIN. RAIL DIMENSIONS BASED ON 5/8" [15.9] STOP HEIGHT AND 1/8" [3.2] TOP DOOR GAP.

**NOTES:**

1. DRAWING IS NOT TO SCALE.
2. DIMENSIONS IN INCHES [MM]
3. LEFT HAND DOOR SHOWN. FOR RIGHT HAND DOOR REVERSE IMAGE.
4. DIMENSIONS BASED ON 4-1/2" X 4-1/2" BUTT HINGES.
5. DOOR SWING MAY BE ALTERED DUE TO OTHER LIMITING CONDITIONS.
6. CAUTION: SEX NUTS MAY BE REQUIRED FOR UNREINFORCED DOORS OR COMPOSITE FIRE DOORS. CONSULT MANUFACTURER'S RECOMMENDATIONS.
7. HOLD OPEN ARMS CAN NOT BE USED ON LABELED FIRE DOORS.
8. ALWAYS CHECK PDQ WEBSITE FOR THE MOST RECENT REVISION AT WWW.PDQLOCKS.COM.