

REQUIRED HOLES	FUNCTION				
	04, 44	06, 13, 15, 43,46	10, 40	73, 74	75,76
HOLE 1		X		X	X
HOLE 2	X				X

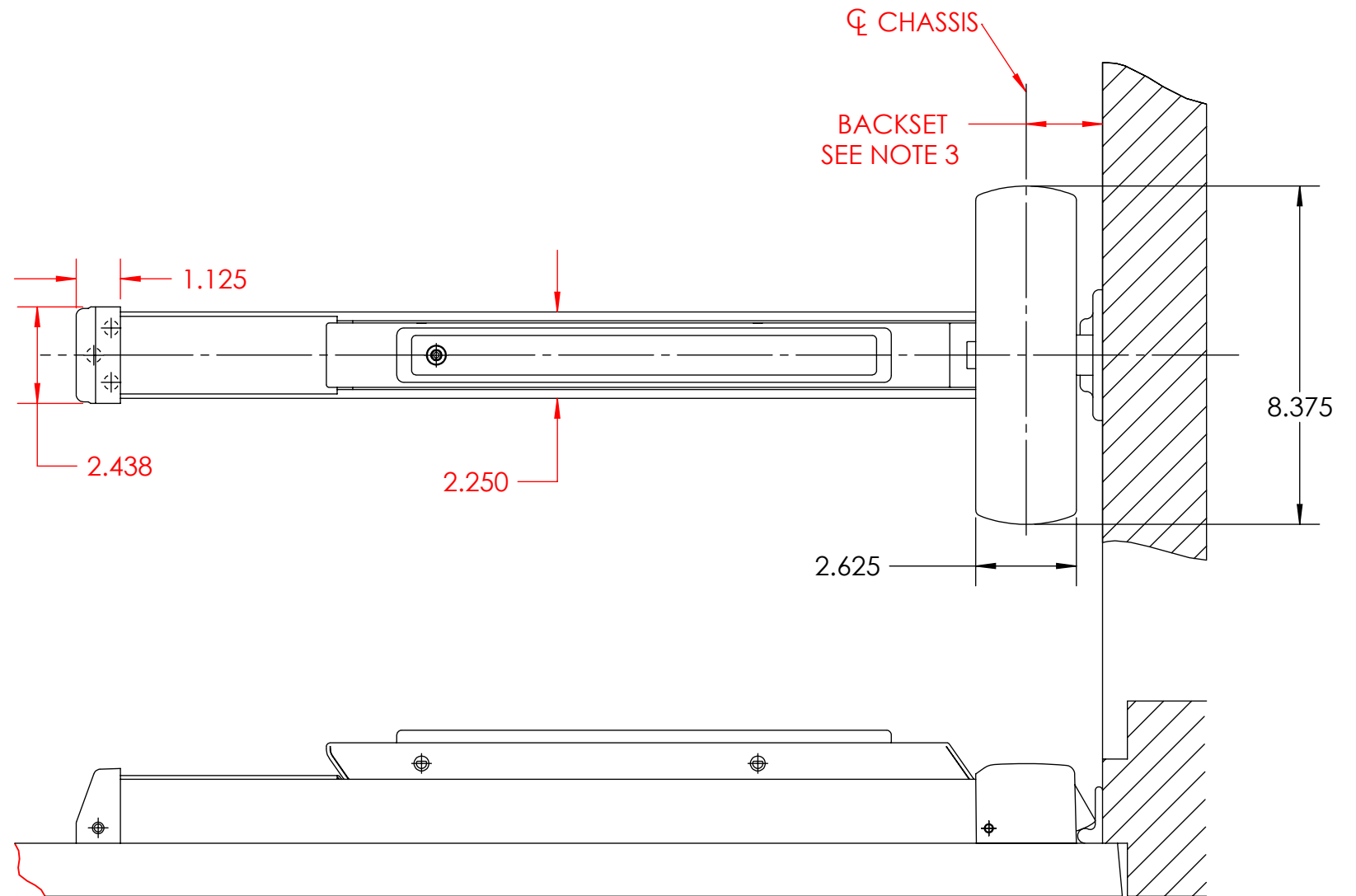
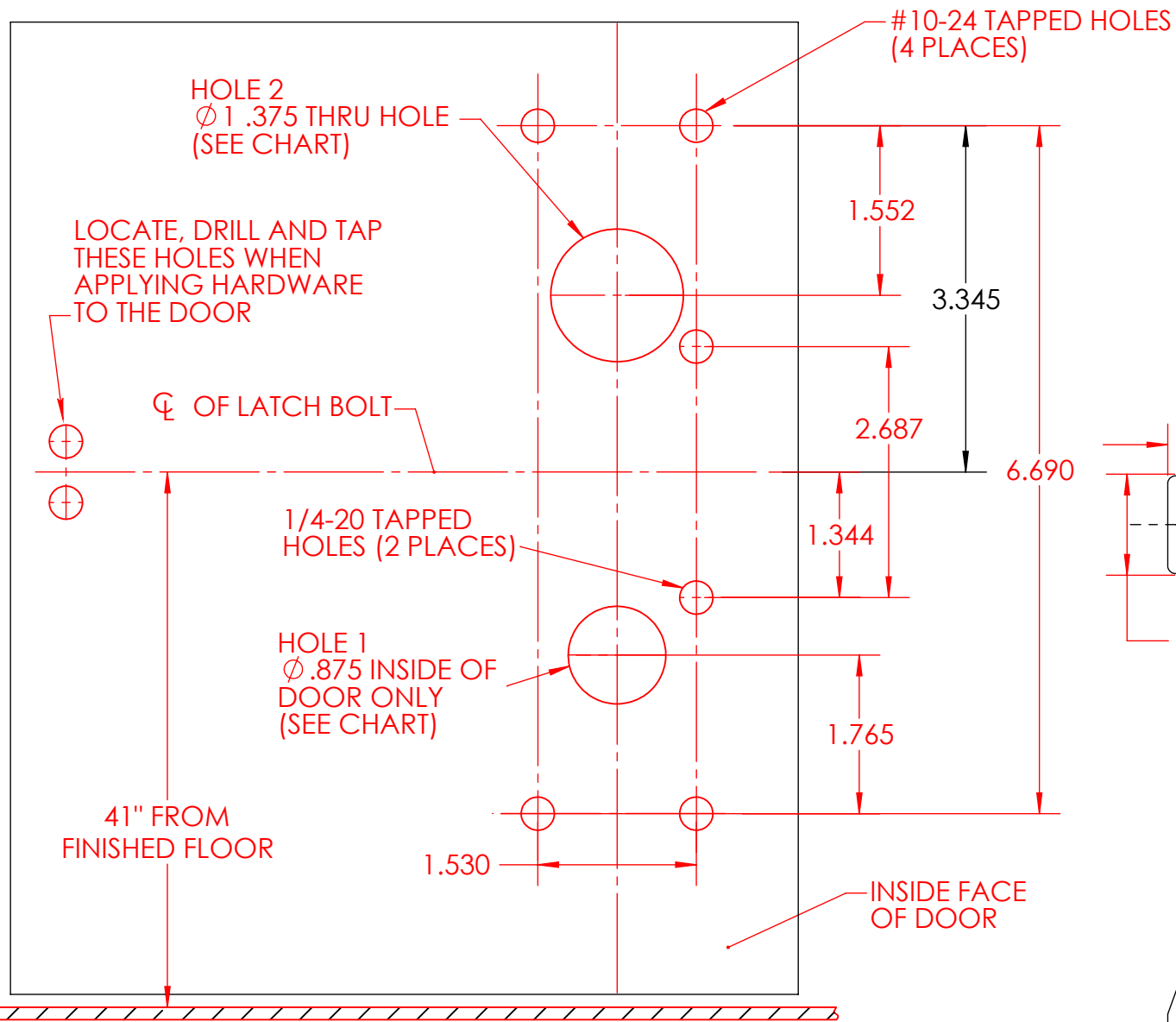

NOTES:

1. TOLERANCE ON ALL DIMENSIONS $\pm .031$.
2. WE RECOMMEND THAT ALL TAPPED HOLES BE DRILLED & TAPPED IN FIELD.
3. SEE STRIKE TEMPLATE FOR VERTICAL CENTER LINE OF CHASSIS.
4. SEE MASTER SHEET No. 4019 FOR AREAS REQUIRING REINFORCEMENTS.
5. SURFACE OF DOOR WHERE EXIT DEVICE IS TO BE APPLIED MUST BE FLUSH.
6. FOR GLASS BEADED DOORS, IF BEAD CANNOT BE REMOVED, USE GLASS SHIM KIT (AVAILABLE ON ORDER).
7. SEE TRIM TEMPLATES FOR OUTSIDE FACE PREPARATION.
8. SEE TEMPLATES No. 4569 & 4571 FOR ELECTROLYNX DETAILS WHEN NEEDED.

SARGENT ASSA ABLOY	SARGENT Manufacturing Company 100 Sargent Drive New Haven, CT 06511
	DOOR MANUFACTURERS TEMPLATE: 8800, 12-8800, 8888, 12-8888, WS- 8800, AND 12-WS 8800 SERIES RIM EXIT DEVICE
RELEASE DATE 25 FEB 06	TEMPLATE NO. 4415 H