

Installation Instructions

SARGENT

ASSA ABLOY

10X Line with BHW Trim

1

Tools Required

- 5/32" drill bit
- 1/2" drill bit
- 7/16" drill bit
- 1/8" drill bit
- #2 Phillips screwdriver
- T25 Security Torx® screwdriver
- T15 Security Torx® screwdriver

2

Product Components

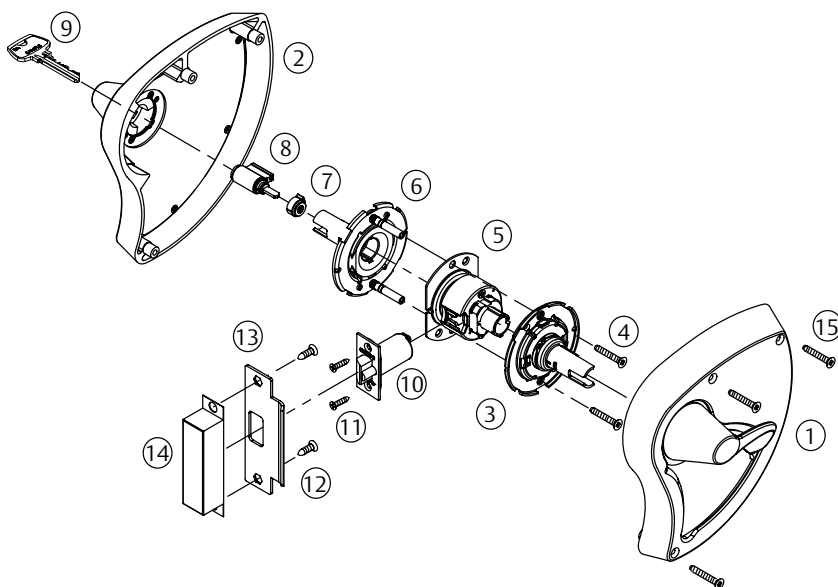

Fig.	Description
1	Inside escutcheon & lever assembly
2	Outside escutcheon & lever assembly
3	Inside spring housing assembly
4	Screws - through-bolt (2) #10-32 x 1-1/4"
5	Lockbody assembly with mounting plate
6	Outside spring housing assembly
7	Cylinder spacer
8	Cylinder
9	Key
10	Latch
11	Screws - latch (2) #8-32 x 3/4"
12	Screws - strike (2) #12-24 x 3/4"
13	Strike
14	Strike box (Optional)
15	Screws- through-bolt (3) #10-24 x 3-1/2"

3

Door Preparation

1. Use template A8335 to mark the door (Figure 1).
2. Drill the door according to the template.
3. Verify the dimensions (Figure 2).
4. Install the strike (Figure 3)

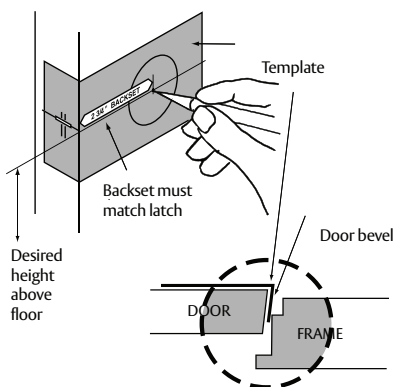

Figure 1

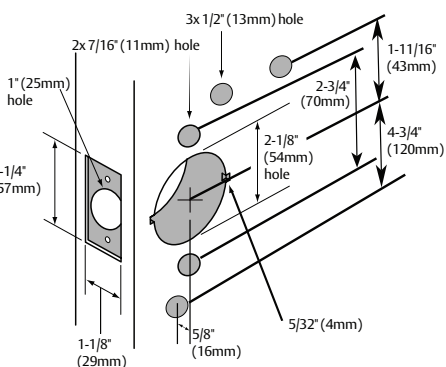

Figure 2

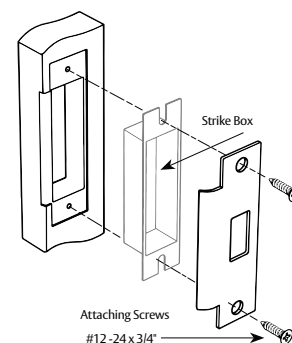

Figure 3

IMPORTANT

- The accuracy of door preparation is critical for proper functioning and security of this lever handle lock. Misalignment can cause premature wear and a lessening of security.
- Be sure to verify backset before marking and drilling door.

For installation assistance contact SARGENT
1-800-543-3658 • techsupport.sargent@assaabloy.com • www.sargentlock.com

Copyright © 2022, 2024, ASSA ABLOY Access and Egress Hardware Group, Inc. All rights reserved. Reproduction in whole or in part without the express written permission of ASSA ABLOY Access and Egress Hardware Group, Inc. is prohibited.

A8334 06/24

Experience a safer
and more open world

4

Latch Installation

Insert latch in door. (Be sure bevel edge of bolt faces strike plate.)
Attach with (2) #8-32 x 3/4" screws supplied.

Important: Deadlocking latch must stop on strike when door is closed.

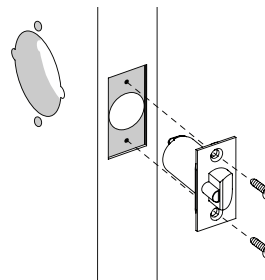

Figure 4

5

Door Thickness Adjustment (if necessary)

Lock is factory preset for 1-3/4" (44mm) doors unless specified. To adjust lock to door thickness if other than 1-3/4" (44mm):

1. Remove outside spring housing from lockbody assembly.
2. Rotate mounting plate to adjust for proper door thickness.
 - For 2" thick door the inside face of the mounting plate should be flush with the face of the bearing. (Figure 5)
 - Verify correct position from the markings on the through-bolt stud, or by measuring from inside surface of the mounting plate to the centerline of the retractor. (Figure 6)
3. Reassemble outside spring housing onto lockbody assembly.

Door Thickness	Dimension A
1-3/4" (44 mm)	7/8" (22 mm)
2" (50 mm)	1" (25 mm)

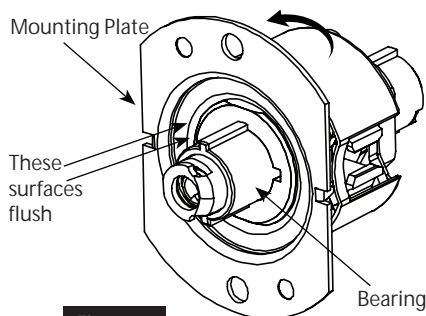

Figure 5

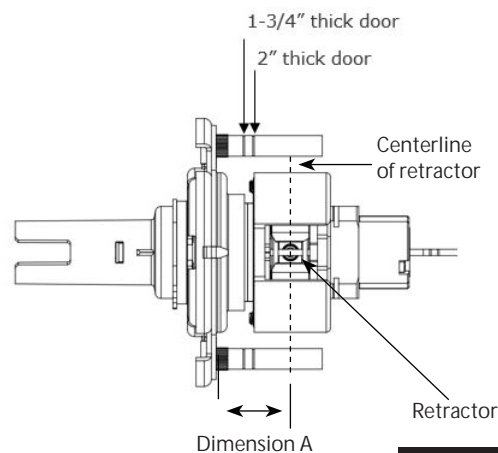

Figure 6

6

Install Outside Lockbody Assembly

To adjust lock to door thickness if other than 1-3/4" (44mm) refer to Section 5.

Insert lockbody assembly into door from outside making sure that lockbody hooks latch case and retractor engages bolt tail(s). (Figure 7)

DO NOT FORCE. (If lockbody does not engage latch easily, check door preparation for errors.)

Latch bolt tail should be centered in depth of retractor. If it is not, refer to Section 5 to properly adjust the lock for door thickness.

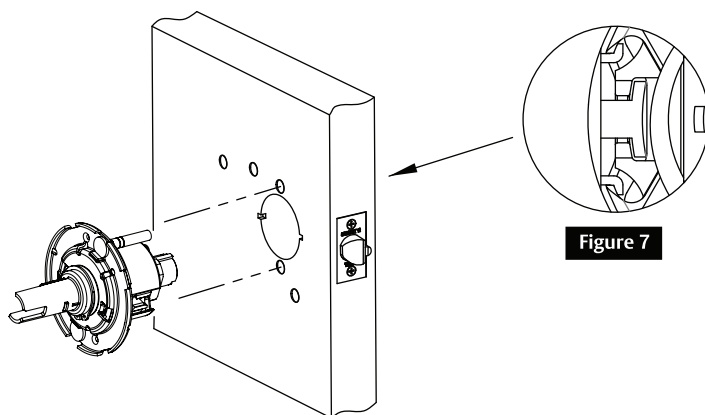

Figure 7

7

Cylinder Installation

a

Standard Cylinder (Figure 8)

IMPORTANT

Before installing cylinders:

- Use a flat blade screwdriver to rotate cam until the driver points are in a 6 and 12 o'clock position. (Figure 8A)

Cylinder spacer should be installed "snapped" on to the cylinder before installing into the outside trim assembly.

1. Install cylinder into the lever. (Figure 8B)

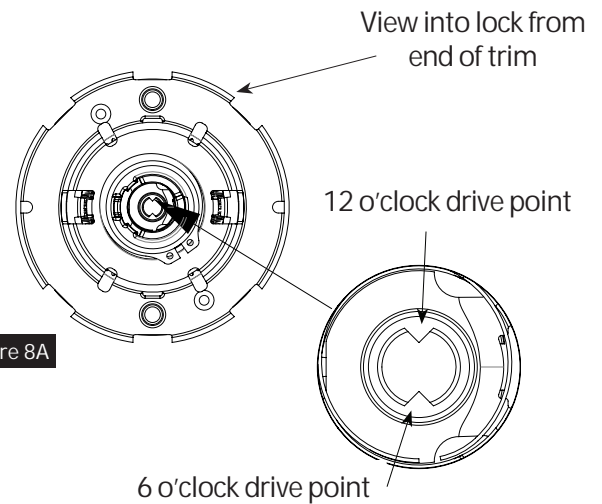

Figure 8A

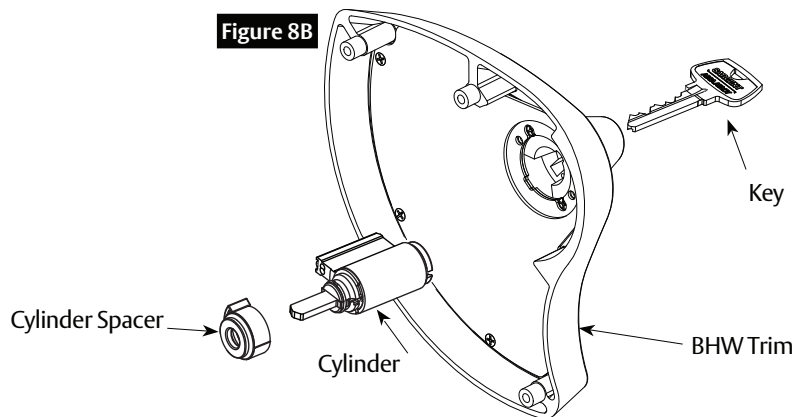

Figure 8B

b

Interchangeable or Removable Core (Figure 9)

- Remove temporary construction core or plastic core. If keyed, use Control Key. Rotate 15° and pull.
- Insert permanent core into lever with control key. Rotate 15° and remove key.

Figure 9

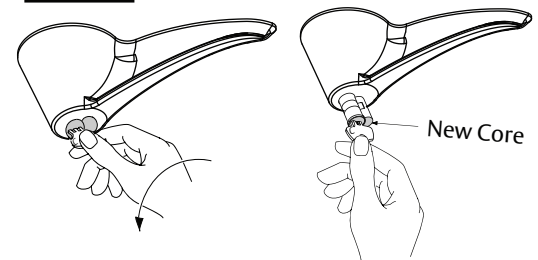

IMPORTANT

- Remove tailpiece from construction core and insert into new core. If using 7 pin cores, insert the 7 pin tail piece that's supplied with the lock, before installing the core into the lock.
- For XC LFIC cores, snap-on retainer must be installed onto tailpiece. Tail and retainer assembly will press fit onto back of core.

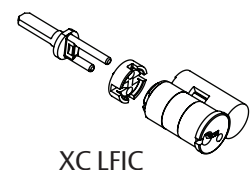

XC LFIC

8

Install Inside and Outside Escutcheon & Lever Assemblies

1. Align and insert inside spring housing onto the installed lockbody.
2. Install (2) #10-32 x 1-1/4" screws to tighten the spring housing to the door.
3. Mount inside escutcheon and lever assembly over the inside spring housing.
4. Mount outside escutcheon and lever assembly over the outside spring housing.
5. Secure the assemblies using the (3) screws #10-24 x 3-1/2" (Figure 10)

Figure 10

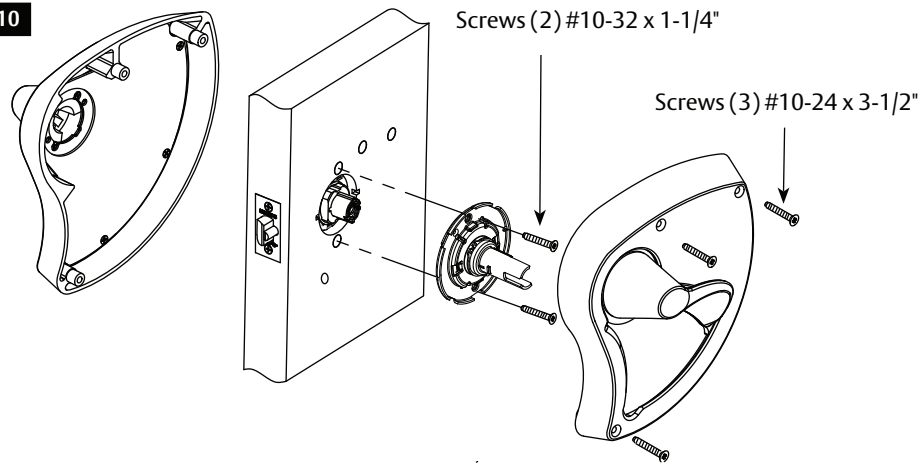

9

Cylinder Options

a

Lever to Accept Schlage® or ASSA ABLOY ACCENTRA™ Fixed Core Cylinder (30- or YC- Option)

1. Provided less cylinder.
2. Depress cap pin and unscrew end cap to remove tailpiece from competitor's cylinder. (Figure 11)
3. Insert new tailpiece in orientation shown.
4. Reassemble end cap over new tailpiece.

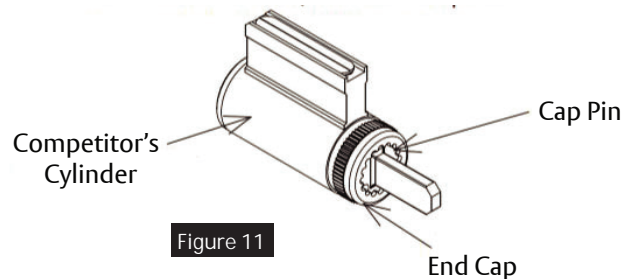

Figure 11

! WARNING

This product can expose you to lead which is known to the state of California to cause cancer and birth defects or other reproductive harm. For more information go to www.P65warnings.ca.gov.