

HOLE ARRANGEMENT FOR 4870 SERIES LOCK

LOCK FUNCTION	OUTSIDE	INSIDE
4874	CYLINDER	CYLINDER
4875	CYLINDER	THUMB TURN
4876	CYLINDER	-
4877	CYLINDER	THUMB TURN
4878	CYLINDER	CYLINDER & THUMB TURN
4879	-	THUMB TURN

DO NOT SCALE

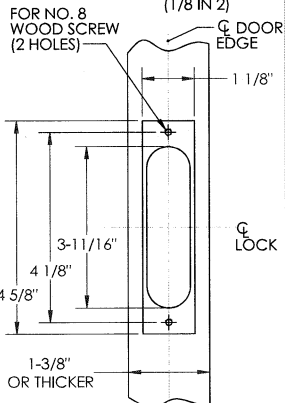
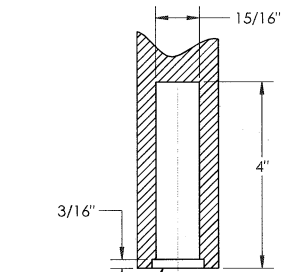

WOOD DOOR PREPARATION SHOWN (FOR HOLE CUT OUTS USE METAL DOOR DIMENSIONS)

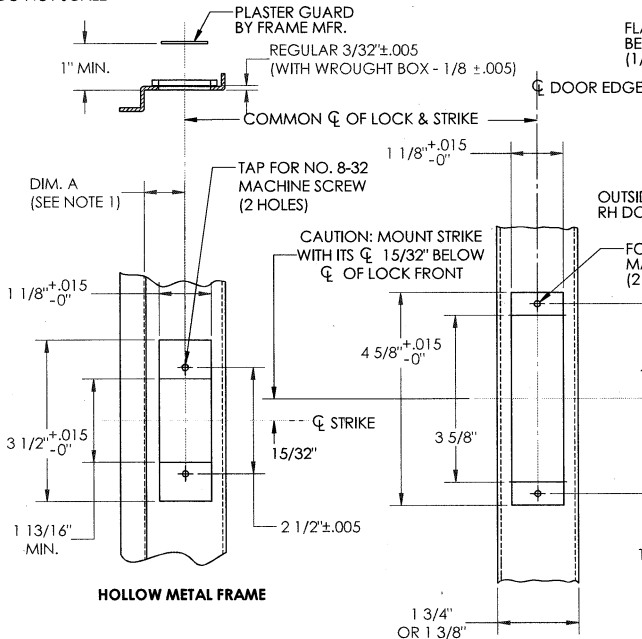

HOLLOW METAL FRAME

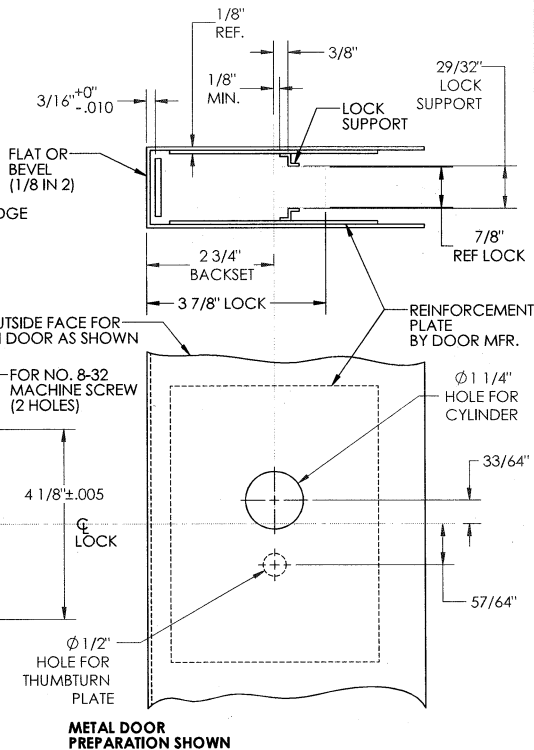

METAL DOOR PREPARATION SHOWN

NOTES:

1. DIMENSION "A" = 1/2 DOOR THICKNESS PLUS CLEARANCE FOR SILENCERS OR GASKETING WHEN USED. (FAILURE TO PROVIDE CLEARANCE WILL CAUSE MISALIGNMENT OF LOCK AND STRIKE, REQUIRING STRIKE MODIFICATION).
2. TOLERANCES SHOWN ARE FOR CUTOUTS.
3. ALL DIMENSIONS GIVEN ABOUT CENTERLINES MUST BE CENTRAL WITHIN TOLERANCE UNLESS OTHERWISE SPECIFIED.

SARGENT Manufacturing Company
100 Sargent Drive New Haven, CT 06511

TEMPLATE: MORTISE LOCK
4870 SERIES
LOCK ONLY

RELEASE DATE

TEMPLATE NO.
4241H